

ZG 501 Padvault—Single-Phase Residential, 4' x 4' (48" x 48")

1. Scope

This specification outlines the minimum requirements for a 48" x 48" padvault for single-phase primary service. Single-phase transformers and sectionalizers (elbow-switched cabinets) can be mounted on this padvault. This specification applies to all single-phase residential padvaults installed by company personnel, contractors, customers, or suppliers.

2. Applicable Documents

The latest revisions of the documents, standards, codes and requirements listed below, in effect on the date of invitation to bid, apply to the extent specified herein.

2.1. Company Material Specifications

ZG 301, General Equipment Base and Enclosure Requirements
ZG 311, Concrete Requirements
ZG 811, Full Traffic Cover and Frame Assembly

2.2. Codes and Standards

Western Underground Committee Guide 2.13, Security for Padmounted Equipment Enclosures
ASTM C857 A-16 (for vaults beneath roadways)
ASTM C857 A-8 (for vaults beneath incidental light truck traffic)

3. Definition

Company refers to PacifiCorp.

PacifiCorp refers to Pacific Power and Rocky Mountain Power.

4. General

This specification states material and construction requirements applicable to this single-phase padvault.

5. Stock Item Numbers

The materials described in this document are assigned the following company stock item numbers.

7999607—PADVAULT, 4' x 4', XFMR/SEC, 1-PH, GG
7992878—VAULT, MANHOLE, 4' x 4', INCIDENTAL TRAFFIC COVER (RATING ASTM C857 A-8)
7992879—VAULT, MANHOLE, 4' x 4', FULL TRAFFIC COVER (ASTM C857 A-16)

6. Design and Manufacturing Requirements

The purpose of a single-phase padvault is to support single-phase transformers or single-phase sectionalizers. ASTM C857 A-16 applies to wall strength. Walls shall be strong enough to hold pulling irons with a 1200 lb. pull strength. A vault beneath incidental light truck traffic shall meet ASTM C857 A-8.

6.1. Padvault Layout

Unless otherwise approved by company engineering, all dimensions and placement of hardware shall conform to those shown in Figure 1 and Figure 2.

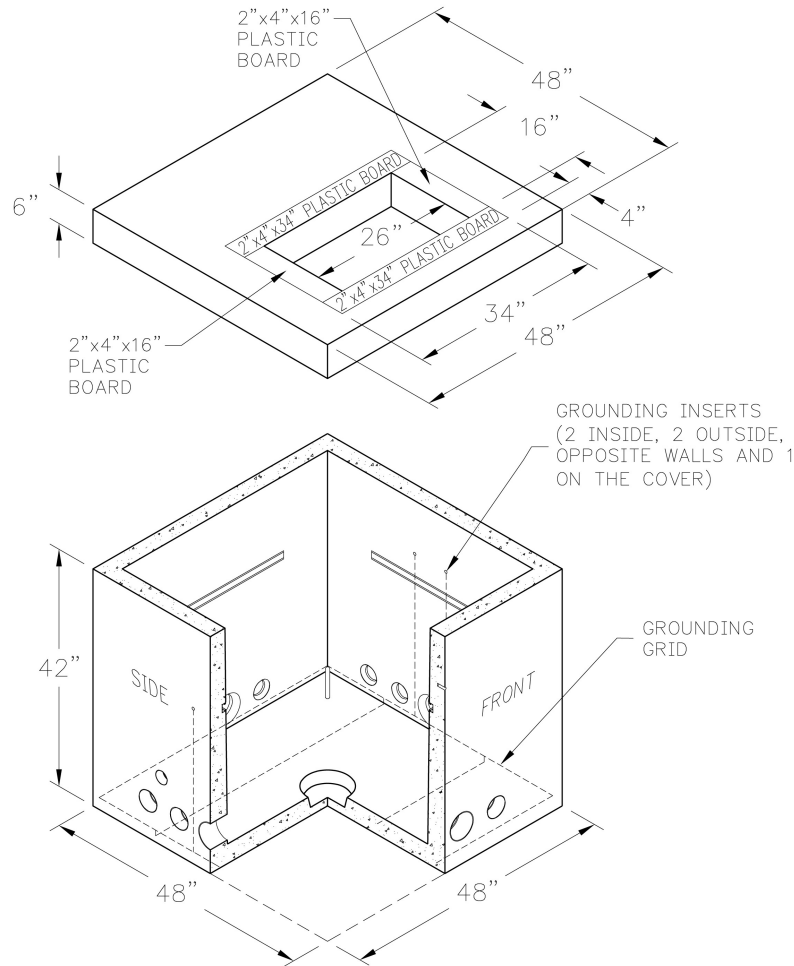

Figure 1— Single-Phase Pad for Sectionalizing Cabinets and Transformers, Vault and Grounding Grid (SI# 7999607)

6.2. Mounting and Mounting Hardware

The supplier shall provide:

- two 2" x 4" x 34" and two 2" x 4" x 16" composite boards for transformer or sectionalizing cabinet, cast flush with the top of the padvault lid, at the locations specified in Figure 1.
- four 1¼" x 2½" stainless steel hold-down cleats with ¼" lift and $\frac{9}{16}$ " x 1½" holes.

All loose hardware shall be packaged, and the package shall be attached to one of the padvault walls.

6.3. Lifting Attachments and Pulling Attachments (Pull-Lift Irons)

Enough lifting attachments shall be provided to ensure safe installation at the site. If the lifting irons attach on the floor in the corners, pull-lift irons may be used for both lifting and pulling. All iron components on the exterior of the walls and floors shall be galvanized. Attachments shall not be placed in front of entrance ports. Pulling irons shall have a minimum holding strength of 1200 lbs.

6.4. Grounding Grid

Each vault shall be constructed with an encased electrode meeting NESC 094.B.6. The $\frac{3}{8}$ " steel rebar shall be 20 continuous feet in length, embedded in concrete at least 24" below finished grade when the vault is set. The grounding system attaches to a connection insert of high-strength bronze alloy, threaded to ½" 13 UNC. The vertical rebar attaching to the bronze connection shall be welded or connected by a minimum of a copper clad $\frac{5}{8}$ " ground clamp.

Each padvault shall have five grounding inserts: Two on opposite side walls and one at the cover. Two inserts on opposite side walls shall be available for connection on the inside and outside of the vault. The outside grounding inserts shall be centered on the side walls. The inside inserts shall be centered on the side wall or located no less than 6" from diagonal corners. The cover pad grounding insert shall be accessible from inside the vault. See Figure 2 for more details.

6.5. Terminal Duct Entrances

The units shall be constructed with terminal duct entrances compatible with PVC or Polyethylene (PE) schedule 40 duct. The wall terminations shall be as shown in Figure 2.

Terminal duct entrance requirements are:

- Four (4) — 2.38" entrances for 2" TERM-A-DUCT
 - Twelve (12) — 3.5" entrances for 3" TERM-A-DUCT
 - Six (6) — 4.5" entrances for 4" TERM-A-DUCT
- Twenty-two (22) total entrances.

ZG 501 Padvault—Single-Phase Residential, 4' × 4' (48" × 48")

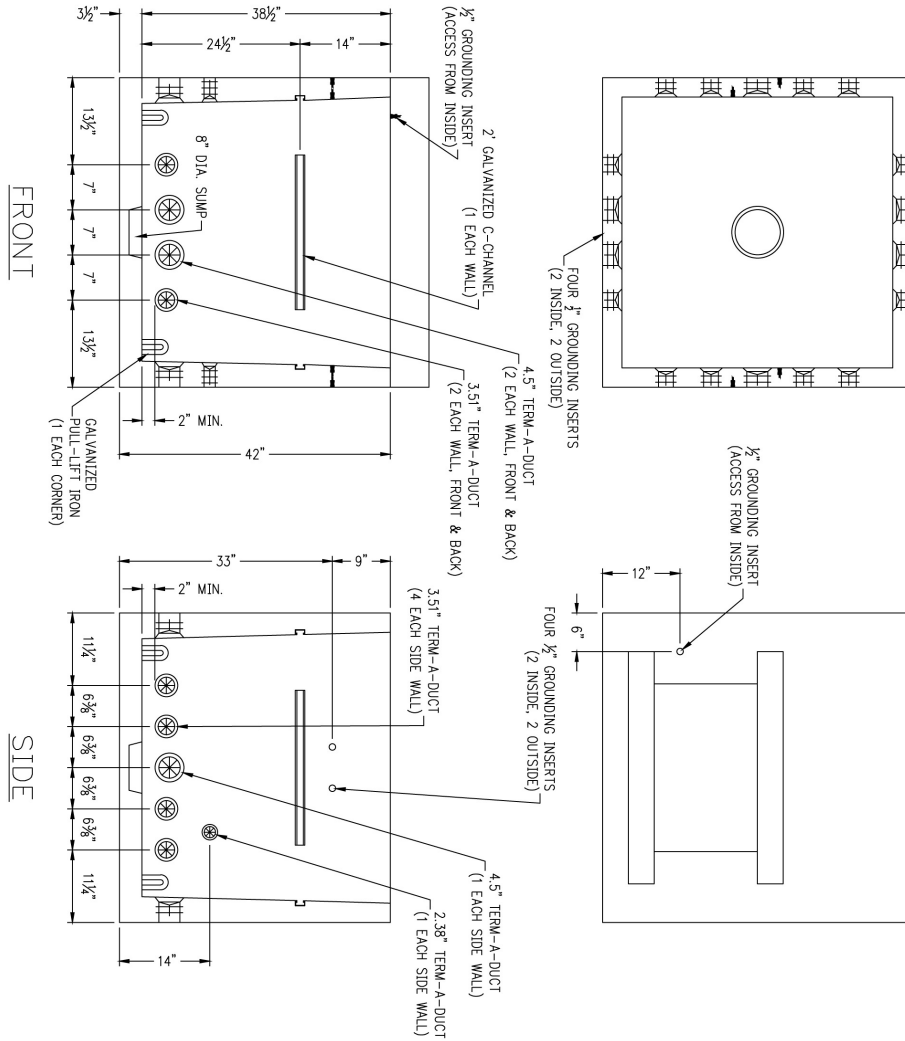
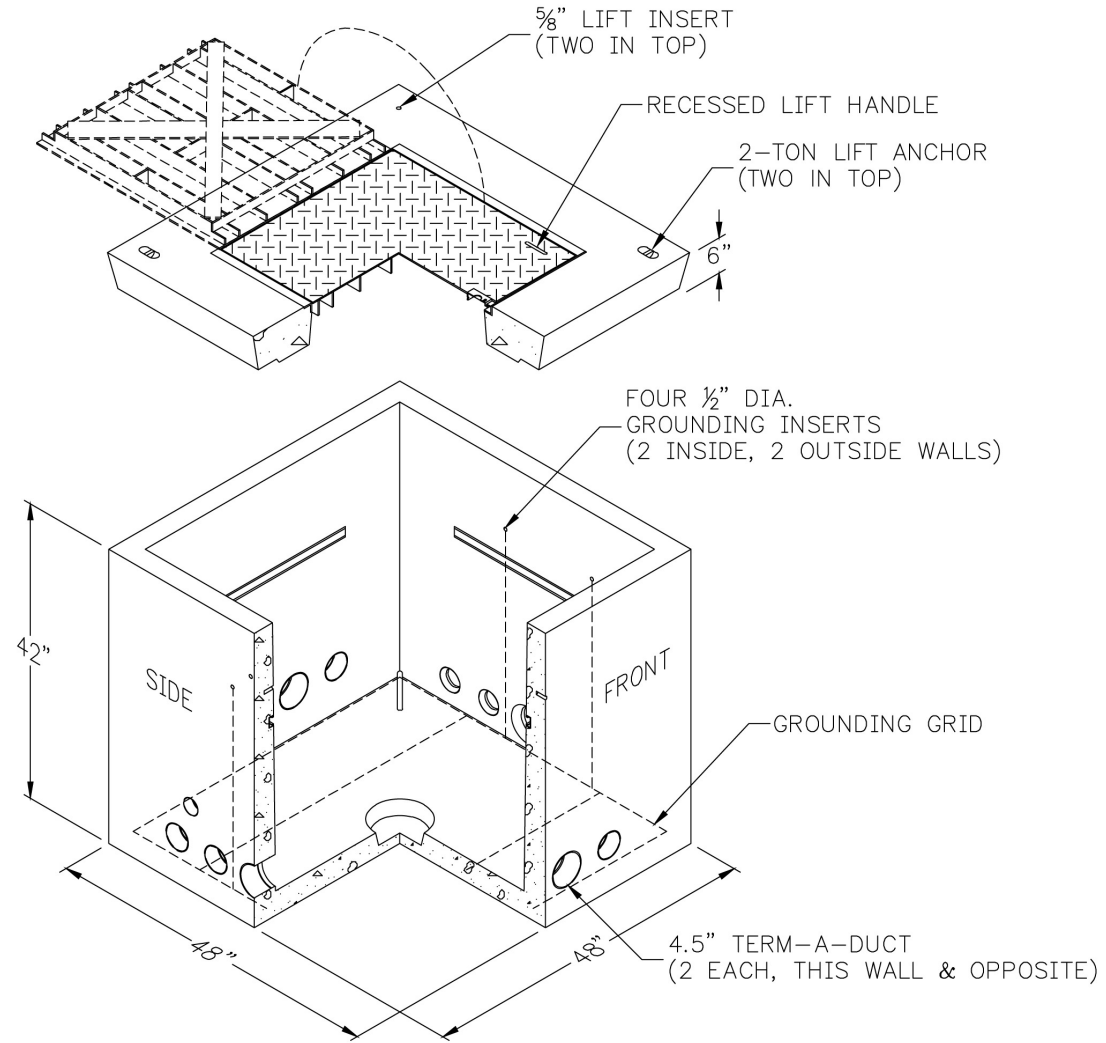

Figure 2— 4' x 4' Vault Layout



**Figure 3— 4' x 4' Manhole Incidental-Traffic Cover (SI# 7992878)
(Splice Vault)**

ZG 501 Padvault—Single-Phase Residential, 4' x 4' (48" x 48")

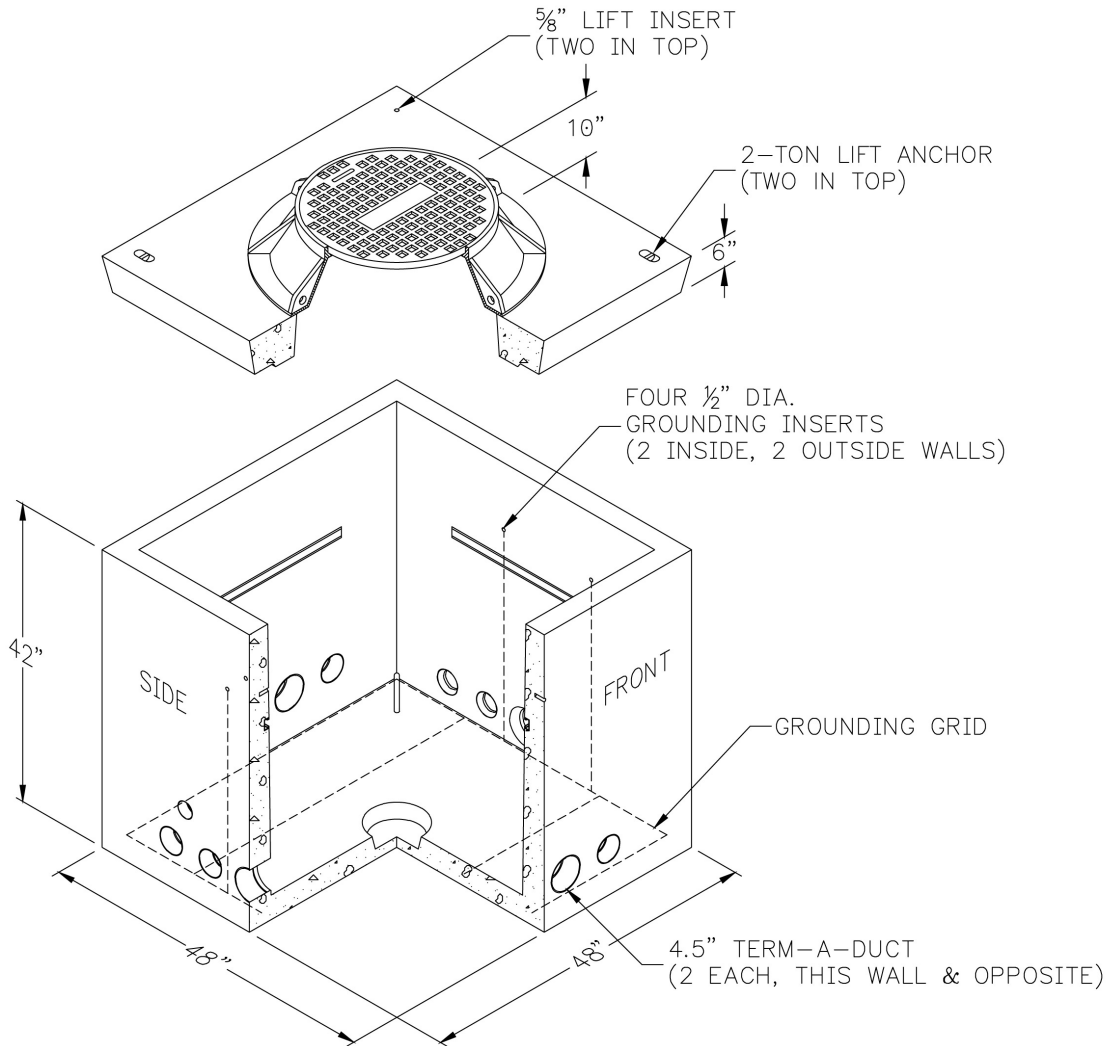

Figure 4— 4' x 4' Manhole Full-Traffic Cover (SI# 7992879)

7. Incidental Traffic Access Cover (SI #7992878 Only)

Vaults and covers that will bear incidental light truck loads shall be rated for such traffic, meeting ASTM C857 A-8 and company material specification ZG 811.

8. Full Traffic Access Cover (SI# 7992879 Only)

Vaults and covers that will bear heavy traffic loads shall be rated for full traffic, meeting AASHTO H-20 and company Material Specification ZG 811. Additional rings may be used to bring the cover to grade (see ZG 811 for grade rings).

This unit shall be set at the site by the supplier. The contractor is responsible to ensure that all earth under the manhole is compacted to within a 2% slope prior to setting the manhole. A clean 6" base of 3/4"-minus gravel shall be provided under the pad, and must be compacted to 90% of dry density.

The interface between the cover/frame assembly and the enclosure should be sealed using a water-proof substance, such as tar or mastic. The top of the pad shall be two to four inches above the final grade in non-pedestrian areas, or flush with grade in pedestrian areas. Setting depth shall be determined by the local regulatory authority for full-traffic areas.

9. Testing

9.1. Test Compliance

Padvaults submitted under this specification shall meet all tests and requirements contained in ZG 301, General Equipment Base and Enclosure Requirements, ZG 311, Concrete Requirements, and this specification. Padvaults will also comply with requirements in applicable national standards.

9.2. Security Test

Transformer padvaults must be able to pass the following security test. The security test is designed to ensure that padmount equipment, which complies with Western Underground Committee Guide 2.13, Security for Padmounted Equipment Enclosures, is not compromised by uneven pad setting.

With the appropriate transformer mounted, attempt to pass a #14 AWG soft-drawn copper wire through the interface between the cabinet and pad. If the wire can be passed through, the pad-vault has failed the test and is not acceptable.

10. Material Specification Issuing Department

The T&D standards engineering departments of PacifiCorp wrote this material specification. This material specification shall be used and duplicated only in support of company projects.

This page is left blank intentionally.