

Padvault—7-Foot by 9-Foot (84" x 108"), for Three-Phase, 15 kV Padmounted Switchgear

1 Scope

This specification outlines the minimum requirements for 7' x 9' (84" x 108") vaults for three-phase, 15 kV padmounted equipment. This specification applies to all 7' x 9' (84" x 108") padvaults installed by PacifiCorp or its contractors, customers or suppliers.

2 Applicable Documents

The latest revisions of the documents, standards, codes and requirements listed in 2.1, *PacifiCorp Specifications*, and 2.2, *Codes and Standards*, in effect on the date of invitation to bid apply to the extent specified herein.

2.1 PacifiCorp Specifications

ZG 301, *General Equipment Base and Enclosure Requirements*

ZG 311, *Concrete Requirements*

ZG 821, *Incidental-Traffic Cover For Padvaults*

2.2 Codes and Standards

ASTM C857 A-16

AASHTO H-20 (for vaults beneath roadways)

ASTM C857 A-8 (for vaults beneath incidental light truck traffic)

3 General

3.1 Applicability

Material and construction requirements stated in this material specification are applicable only to 7' x 9' (84" x 108") padvaults.

3.2 Authorization

This material specification is not considered valid unless each page contains the approval signature or initials of the persons named in the title blocks.

MATERIAL SPECIFICATION Distribution

© 2011 by PacifiCorp. All rights reserved.

Engineer (E. Maleki): *AEM*
Standards Manager (D. Asgharian): *DDA*

Padvault—7-Foot by 9-Foot (84" x 108"), for Three-Phase, 15 kV Padmounted Switchgear



31 Aug 11

ZG 622
Page 1 of 8

ZG 622

4 Applicable Stock Item Numbers

Materials submitted for the following PacifiCorp stock item number is subject to evaluation according to the requirements in this specification:

7999954, PADVAULT, SWGEAR, 84" × 108", TYPE 9 AND 11, 15 KV, DF

5 Design and Manufacturing Requirements

The purpose of a 7' × 9' (84" × 108") vault is to provide an enclosure for cable pulling and padmounted switching.

5.1 Vault Layout

Figure 1 and Figure 2 show the assembled 7' × 9' (84" × 108") vault layout with dimensions. Unless otherwise approved by PacifiCorp Engineering, all dimensions and placement of hardware shall conform to those shown in Figure 1 and Figure 2. Vault enclosures shall be constructed to the AASHTO H-20 (full traffic) standard, regardless of the cover type and frame assembly.

5.2 Lifting Attachments

Enough lifting attachments shall be provided to ensure safe installation of all pieces at the site.

5.3 Pulling Attachments

Cable pulling attachments shall be installed opposite each set of Term-A-Duct banks, such that blocks may be attached for a straight cable pull. Pulling attachments shall have a minimum pullout strength of 6000 pounds. Attachments shall allow the attachment of a clevis with a one-inch diameter through-bolt. Pulling attachments may be designed by the manufacturer to meet these requirements. (Pulling irons shall not block the front of the terminal duct entrances.)

5.4 Conduit Entrances

The padvault shall be constructed with Term-A-Ducts. The standard conduit entrance locations are as follows, and are also shown in Figure 2.

Each wall: six 6.63" entrances



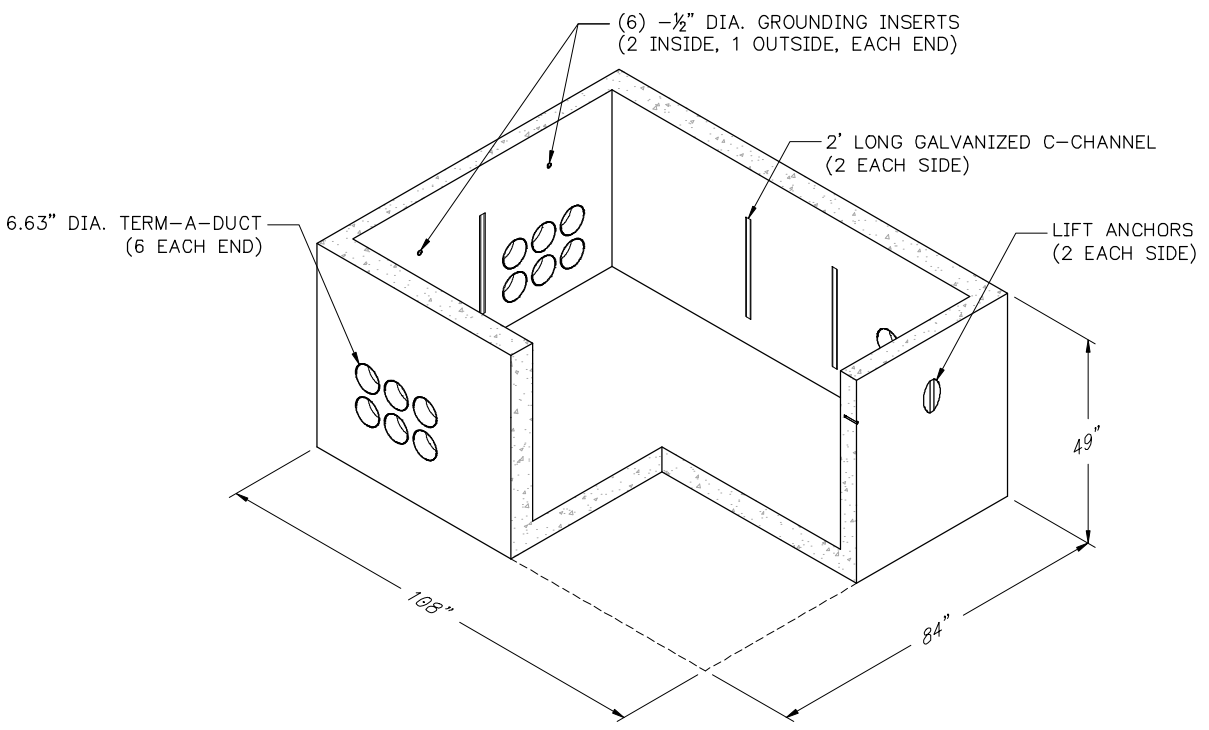



Figure 1—7' x 9' (84" x 108") Vault (Cutaway View)

MATERIAL SPECIFICATION
Distribution
© 2011 by PacifiCorp. All rights reserved.
Engineer (E. Maleki): *AEM*
Standards Manager (D. Asgharian): *DDA*

Padvault—7-Foot by 9-Foot (84" x 108"), for Three-Phase, 15 kV Padmounted Switchgear

 **PACIFICORP**
A MIDAMERICAN ENERGY HOLDINGS COMPANY

31 Aug 11

ZG 622
Page 3 of 8

ZG 622

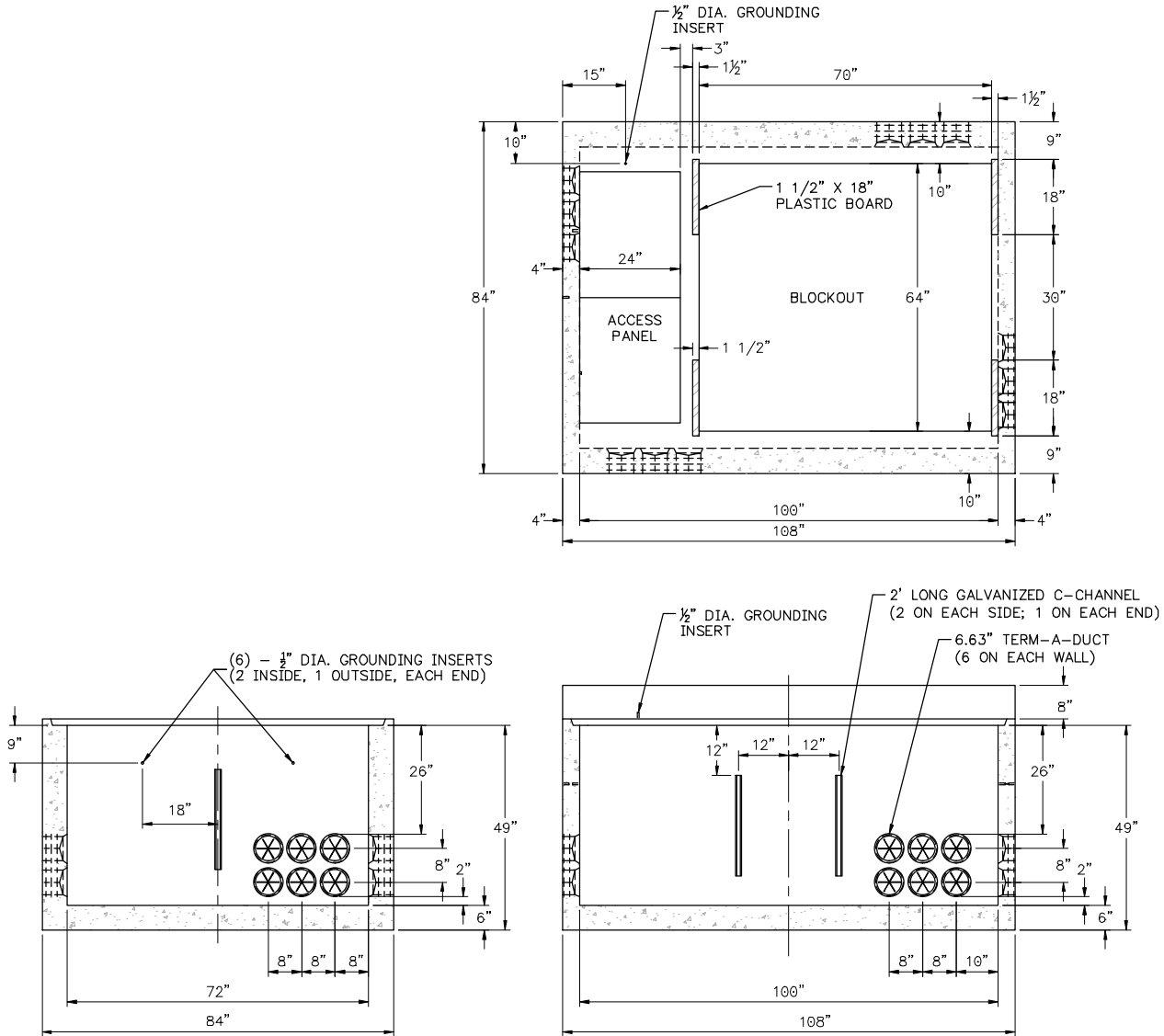

Figure 2—Padvault Enclosure Layout (Top and Side Views)

5.5 Grounding Grid

The vault shall be equipped with an internal, encased electrode in the vault enclosure meeting NESC 094.B.6. The electrode shall be 3/8" steel rebar. It shall be encased horizontally and run continuously around vault, and it shall be a minimum of 24" from the top of the vault. The grounding system shall attach to "connection" inserts, made of high-bronze alloy, and shall be threaded to 0.5"-13UNC. Inserts shall have caps or plugs installed. The padvault shall have seven grounding inserts: one insert on the cover (near the access door), one outside each end wall, and two inside each end wall.



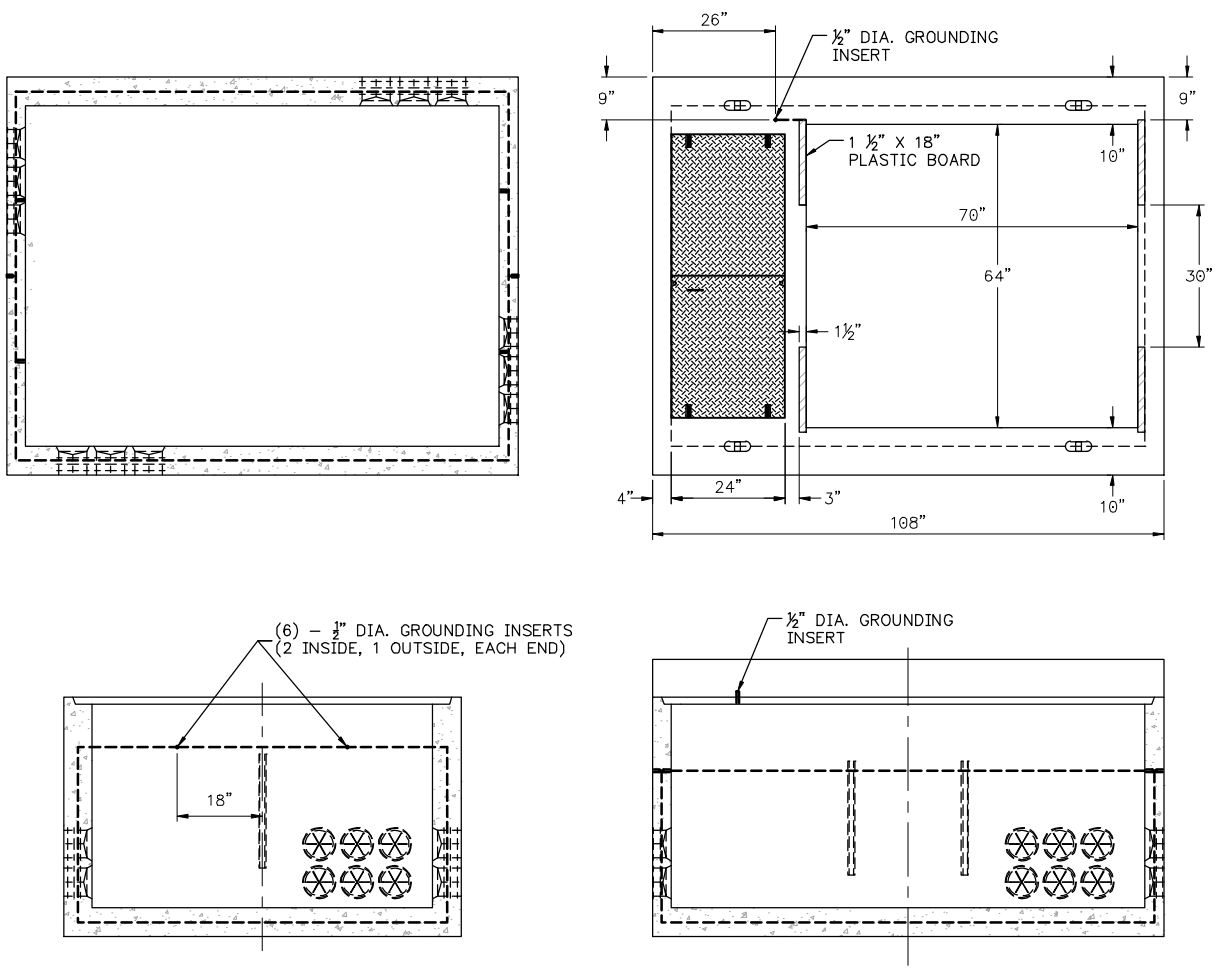



Figure 3—Padvault Ground Grid Layout (Top and Side Views)

<p>MATERIAL SPECIFICATION Distribution</p> <p>© 2011 by PacifiCorp. All rights reserved.</p> <p>Engineer (E. Maleki): <i>AEM</i> Standards Manager (D. Asgharian): <i>DDA</i></p>	<p>Padvault—7-Foot by 9-Foot (84" x 108"), for Three-Phase, 15 kV Padmounted Switchgear</p>	<p> A MIDAMERICAN ENERGY HOLDINGS COMPANY</p> <p>31 Aug 11</p> <p>ZG 622 Page 5 of 8</p>
---	--	--

ZG 622

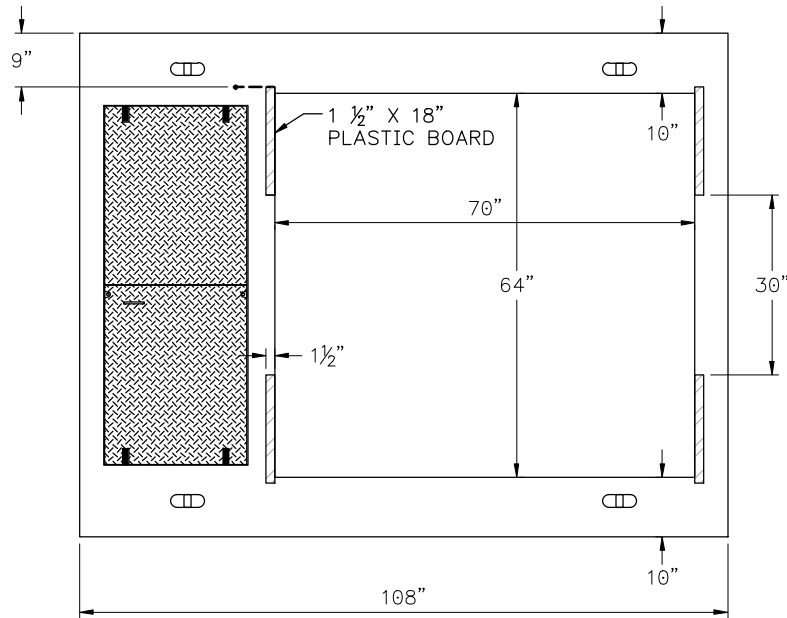

Figure 4—Padvault for 15 kV Switchgear Types 9 and 11 (Top View)

5.6 Installation

The unit shall be set at the site by the supplier. The contractor is responsible for ensuring that the earth under the vault is compacted and leveled to no more than 2% slope prior to setting the vault. A clean gravel base under the padvault may be necessary in areas where drainage is poor. The interface between the pad and the enclosure shall be sealed using a waterproof substance, such as tar or mastic. The top of the frame should be flush with the final grade in pedestrian areas. The setting depth shall be determined by the local regulatory authority for full-traffic areas.

6 Padvault for 15 kV, Three-Phase Switchgear Cabinets

6.1 Padvault Layout

See Figure 4 for padvault layout and dimensions particular to installations with 15 kV, three-phase switchgear, types 9 and 11.

6.2 Inserts and Mounting Hardware

The supplier shall provide:

- four 2" (or 1-1/2") x 4" x 18" composite boards for 15 kV three-phase switchgear. Boards shall be case-flush with the top of the padvault lid at the locations specified in Figure 4.

The following hardware to fasten the switchgear to the composite boards shall be provided:



by PacifiCorp:

- four $1/2" \times 2"$ hot-dip galvanized lag screws (SI# 7992810)
- six stainless steel Belleville washers

by the supplier:

- four $1-1/4" \times 2-1/2"$ stainless steel hold-down cleats with $1/4"$ lift and $9/16"$ $\times 1-1/2"$ holes.

6.3 Access Panel

Three-phase padvaults shall be equipped with one access panel, as described in PacifiCorp Material Specification ZG 821, *Incidental-Traffic Cover For Padvaults*. The access panel size shall not exceed $24" \times 60"$.

7 Testing

7.1 Test Compliance

Vaults submitted under this specification shall meet all tests and requirements contained in material specifications ZG 301, *General Equipment Base and Enclosure Requirements*, ZG 311, *Concrete Requirements*, and this specification. Vaults shall also comply with requirements in applicable national standards.

8 Material Specification Issuing Department

The Engineering and Asset Management Documentation department of PacifiCorp published this material specification. Questions regarding editing, revision history and document output may be directed to the lead editor at (503) 813–5293. Technical questions and comments may be submitted to Ehsan Maleki, Standards Engineering, (503) 813–7089.

This material specification shall be used and duplicated only in support of PacifiCorp projects. This document is considered a valid publication when the signature block in the footer has been initialed by the authoring engineer and standards manager.

MATERIAL SPECIFICATION Distribution

© 2011 by PacifiCorp. All rights reserved.

Engineer (E. Maleki): *AEM*
Standards Manager (D. Asgharian): *DDA*

**Padvault—7-Foot by
9-Foot (84" x 108"), for
Three-Phase, 15 kV
Padmounted
Switchgear**



31 Aug 11

ZG 622
Page 7 of 8

This page is left blank intentionally.



**Padvault—7-Foot by
9-Foot (84" x 108"), for
Three-Phase, 15 kV
Padmounted
Switchgear**

**MATERIAL SPECIFICATION
Distribution**

© 2011 by PacifiCorp. All rights reserved.

Engineer (E. Maleki): *AEM*
Standards Manager (D. Asgharian): *DDA*