

ZG 532 Flat Pad—Three-Phase Transformer

1. Scope

This specification outlines the minimum requirements for flat pads to be used in conjunction with PacifiCorp owned three-phase transformers. The specification applies whether the pad is to be installed by company personnel, contractors, customer, or the supplier.

2. Applicable Documents

The latest revisions of the documents, standards, codes and requirements listed in the following subsections in effect on the date of invitation to bid apply to the extent specified herein.

2.1. PacifiCorp

ZG 301, General Equipment Base and Enclosure Requirements
ZG 311, Concrete Requirements

2.2. Codes and Standards

Applicable codes include:

ACI standards
ANSI standards
IEEE standards
NEMA standards

3. General

This specification states material and construction requirements which are applicable to all three-phase transformer flat pads.

4. Applicable Stock Item Number

Materials being submitted for the following PacifiCorp stock item number are subject to evaluation in accordance with requirements in this specification.

4.1. Stock Item Number

1790021, Pad, Flat, Transformer, Three-Phase, 15-25 kV, 75-500 kVA
1008958, Pad, Flat, Transformer, Three-Phase, 35 kV, 75-500 kVA

5. Design and Manufacturing Requirements

The purpose of a three-phase transformer flat pad is to support the weight of a transformer.

5.1. Loading Design

The pad shall be capable of supporting up to 10,000 lbs. The supplier shall determine the proper placement of steel reinforcement to ensure compliance with strength requirements. Reinforcement shall consist of 4 x 4 - 6/6 steel reinforcing mesh and #4 through #6 steel rebar, placed as required to meet the load requirements of individual equipment base and enclosure specifications. Mesh shall meet the requirements of ASTM A-185. Rebar shall be Grade 60, and shall meet the requirements of ASTM A-615.

5.2. Pad Layout

Unless otherwise approved by PacifiCorp Engineering, all dimensions and placement of hardware shall conform to those shown in Figure 1 and Figure 2 and shown below unless otherwise authorized by PacifiCorp Engineering.

5.3. Mounting and Mounting Hardware

The supplier shall provide:

- two 2" x 4" x 20" composite boards for a three-phase transformer, cast flush with the top of the pad at the locations specified in Figure 1 and Figure 2.
 - PacifiCorp will provide two ½" x 2" hot-dip galvanized lag screws (SI# 7992810) and two stainless steel Belleville washers to fasten the transformer to the composite board. Additional hardware to be provided by the supplier includes:
 - two 1 ¼" x 2 ½" stainless steel hold-down cleats with ¼" lift and 9/16" x 1 ½" holes.

6. Testing

6.1. Test Compliance

Pads submitted under this specification shall meet all tests and requirements contained in ZG 301, ZG 311, and this specification. Pads will also comply with applicable requirements in listed Western Underground Committee guides and national standards.

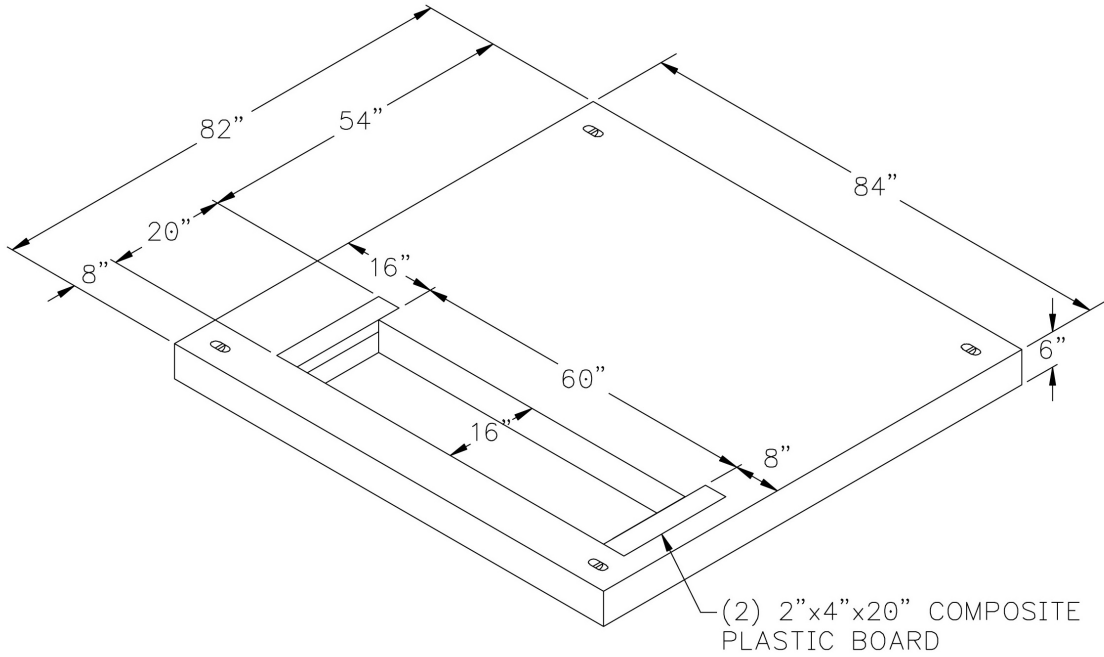

Figure 1—15-25 kV, 75-500 kVA Three-Phase Transformer Flat Pad (SI# 1790021)

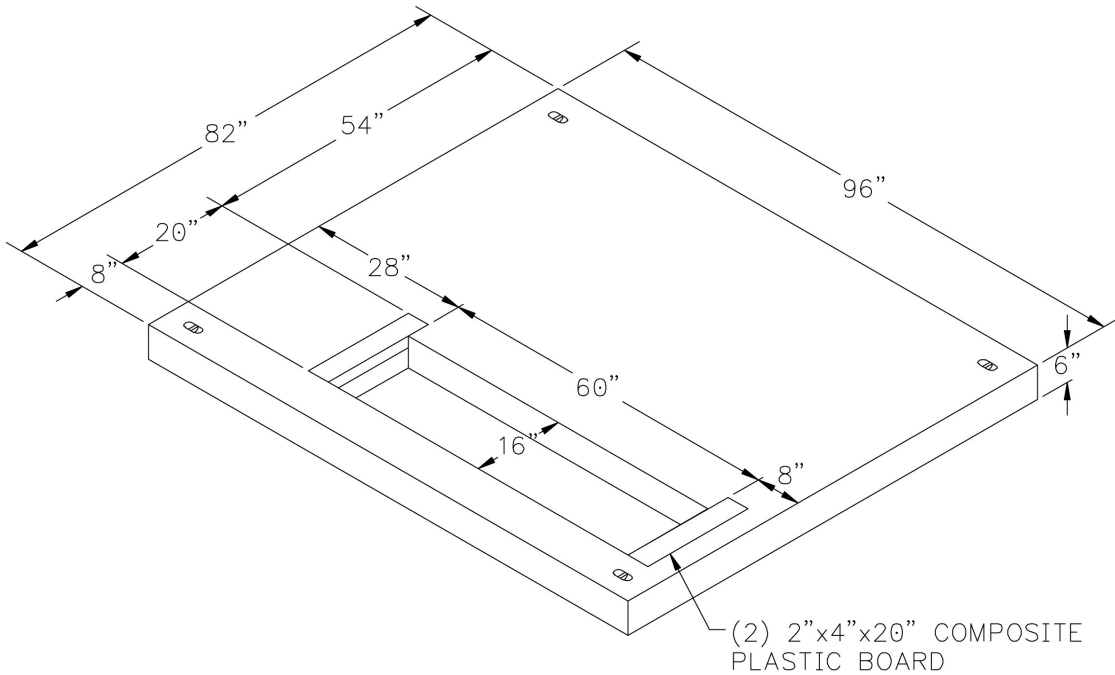

Figure 2—35 kV, 75-500 kVA Three-Phase Transformer Flat Pad (SI# 1008958)

7. Material Specification Issuing Department

The engineering standards and grid modernization department of PacifiCorp published this material specification. This material specification shall be used and duplicated only in support of company projects.