

ZG 616 Padvault—4' x 6' (48" x 72")

1. Scope

This specification outlines the minimum requirements for 4' x 6' padvaults to be used for pad-mounted equipment. The specification applies to all 4' x 6' padvaults installed by the company or its contractors, customers, or suppliers.

2. Applicable Documents

The latest revision of the documents, standards, codes, and requirements listed below, in effect on the date of invitation to bid, shall apply to the extent specified herein.

2.1. Company Documents

ZG 301, General Equipment Base and Enclosure Requirements
 ZG 311, Concrete Requirements
 ZG 821, Incidental Traffic Cover and Frame Assembly

2.2. Codes and Standards

ANSI / SCTE 77 2007
 ASTM C857 A-16 (for vaults beneath roadways)
 ASTM C857 A-8 (for vaults beneath incidental light truck traffic)

3. General

3.1. Applicability

Material and construction requirements stated in this specification are applicable only to 4' x 6' padvaults.

4. Applicable Stock Item Numbers

Materials being submitted for the following company stock item numbers are subject to evaluation according to the requirements in this specification.

7992975, PADVAULT, SECTIONALIZING CABINET, 1-PHASE, 15/25 KV
 7992976, PADVAULT, FUSING CABINET, 1-PHASE, 15/25 KV
 3090368, PADVAULT, METERING, 1-PHASE, 200 A
 7999352, PADVAULT, TRANSFORMER, 1-PHASE, 25—167 KVA
 (horizontal opening)
 7992977, PADVAULT, TRANSFORMER, 1-PHASE, 25—167 KVA (vertical opening)

5. Padvault Base Layout

Figure 1 shows the assembled 4' x 6' vault layout with dimensions. Unless otherwise approved by company engineering, all dimensions and placement of hardware shall conform to those shown in Figure 1. All vault enclosures shall be constructed to AASHTO H-20 (full-traffic) standards, regardless of the cover and frame assembly used.

5.1. Lifting Attachments

Enough lifting attachments shall be provided to ensure safe installation of all pieces at the site.

5.2. Pulling Attachments

Cable pulling attachments shall be installed opposite each set of Term-A-Duct banks, such that blocks may be attached for a straight pull. Pulling attachments shall have a minimum pullout strength of 1200 pounds. Attachments shall allow the attachment of a clevis with a one-inch diameter through-bolt. Pulling attachments may be designed by the manufacturer to meet these requirements.

5.3. C-Channels

Each side of the vault shall be equipped with a C-channel. The C-channel shall be made of galvanized steel or fiberglass, and have dimensions of $1 \frac{5}{8}'' \times 13/16''$. Both ends and both sides shall have two-foot (2') pieces cast flush with the concrete, as shown in Figure 2.

5.4. Conduit Entrances

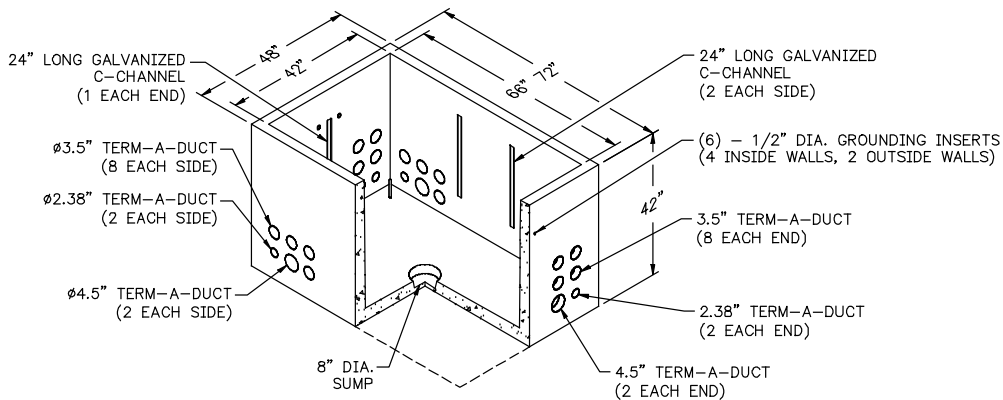

Figure 1— 4' x 6' Padvault, Cutaway View

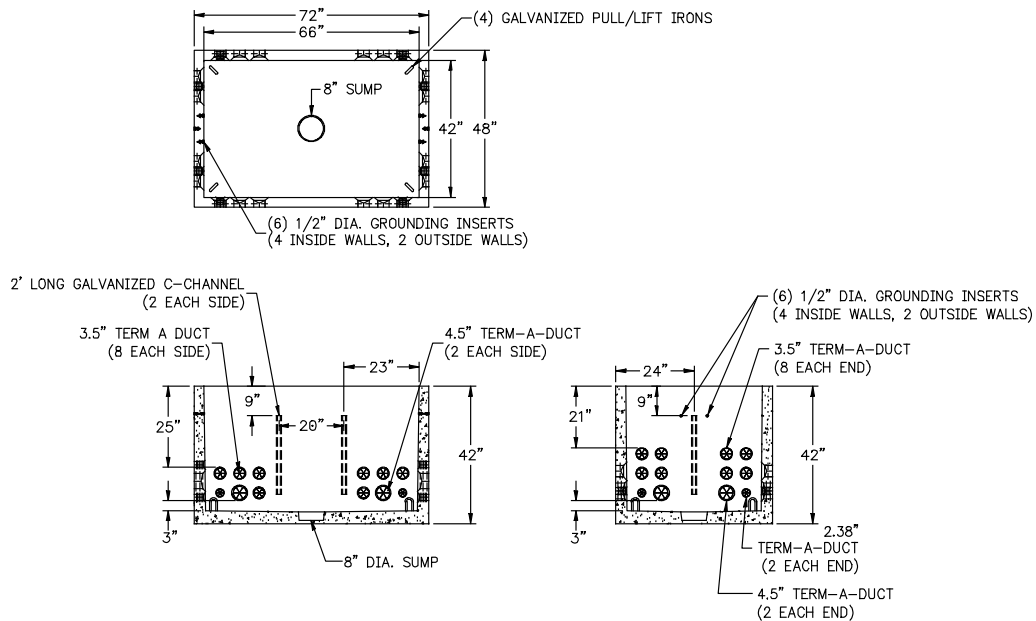

Figure 2— 4' x 6' Padvault, Enclosure Layout

6. Pad Layout

Unless otherwise approved by company engineering, all dimensions and placement of hardware shall conform to those shown in Figure 3, Figure 4, and Figure 5.

6.1. Mounting and Mounting Hardware

For transformers, the supplier shall provide two 2" x 4" x 24" composite boards, cast flush with the top of the padvault lid, at the locations specified in Figure 3 and Figure 4.

For sectionalizing cabinets, the supplier shall provide:

- two 2" x 4" x 36" composite boards, cast flush with the top of the padvault lid, at the locations specified in Figure 5.
- stainless steel hold-down cleats with 1/4" lift and 9/16" x 1 1/2" holes - two cleats for transformer covers; four cleats for sectionalizer covers.

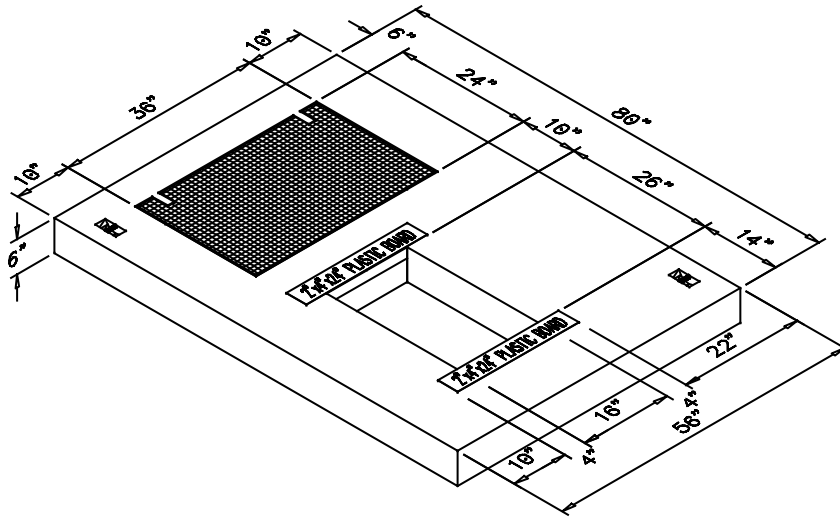

Figure 3 —4' x 6' Single-Phase Transformer Lid, SI# 7992977

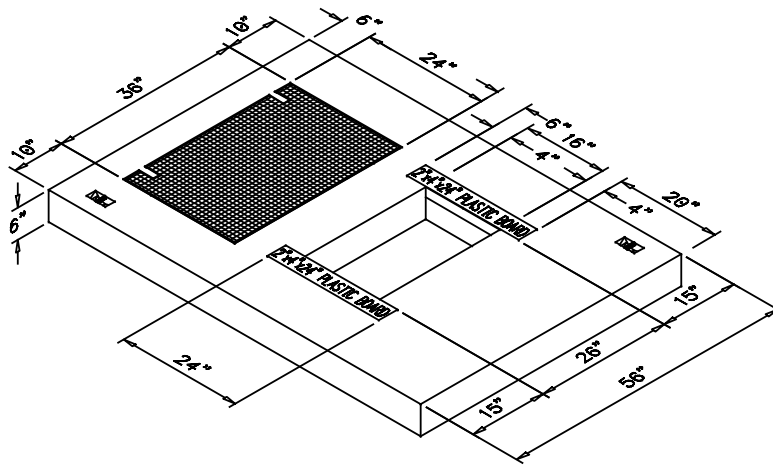

Figure 4 —4' x 6' Single-Phase Transformer Lid, SI# 7999352

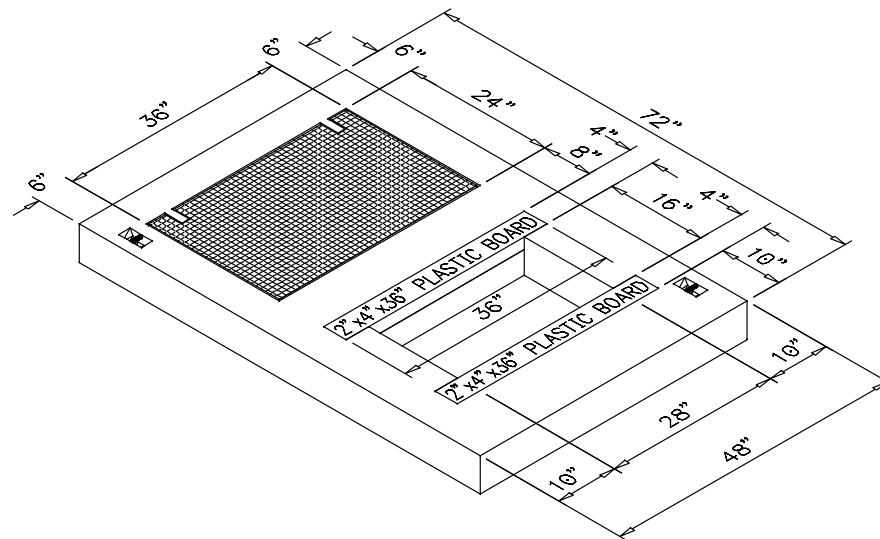

Figure 5 —4' × 6' Single-Phase Sectionalizer Lid, SI# 7992975

6.2. Lifting Attachments and Pulling Attachments (Pull-Lift Irons)

Enough lifting attachments shall be provided to ensure safe installation at the site.

6.3. Grounding Grid

The padvault shall be equipped with an internal, encased electrode in the padvault enclosure meeting NESC 094.B.6. The electrode shall be $\frac{3}{8}$ " steel rebar. The electrode shall be encased horizontally and run continuously around the padvault. The padvault electrode shall be a minimum of 24" from the top of the padvault. The grounding system shall attach to "connection" inserts made of high-bronze alloy and threaded to 0.5" - 13UNC. All inserts shall have caps or plugs installed.

All 4' × 6' padvaults shall have two grounding inserts inside, and one outside of each end wall. The pad shall have one grounding insert on the side of the access door. Refer to Figure 6 for specific layout.

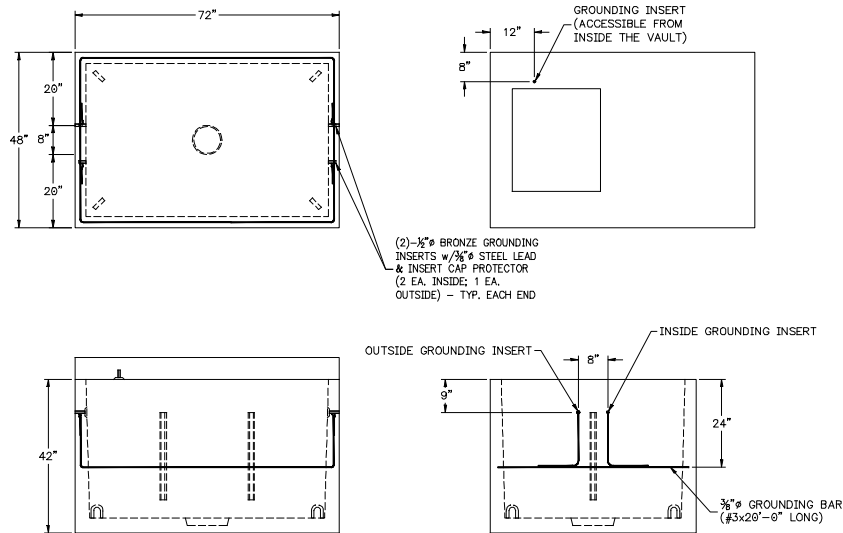

Figure 6—4' x 6' Padvault, Ground Grid Layout

6.4. Installation

The unit shall be set at the site by the supplier. The contractor is responsible for insuring that all earth under the padvault is compacted and leveled to no more than 2% off-level prior to settling the padvault. A clean gravel base under the padvault may be necessary in areas where drainage is poor. The interface between the pad and the enclosure shall be sealed using a waterproof substance such as tar or mastic. The top of the frame shall be flush with the final grade in pedestrian areas. Setting depth shall be determined by the local regulatory authority for full-traffic areas.

7. Testing

Padvaults submitted under this specification shall meet all tests and requirements contained in ZG 301, General Equipment Base and Enclosure Requirements, ZG 311, Concrete Requirements, and this specification. Padvaults shall also comply with requirements in applicable national standards.

8. Issuing Department

The engineering standards and technical services department of PacifiCorp published this material specification. This material specification shall be used and duplicated only in support of company projects.