

ZG 711 Vault—Shallow, 7' × 12' (94" × 155")

1. Scope

This specification outlines the minimum requirements for shallow 7' × 12' (94" × 155") vaults to be used for pad-mounted equipment. The specification applies to all shallow 7' × 12' (94" × 155") vaults installed by the company, contractors, customers, or suppliers.

2. Applicable Documents

The latest revisions of the documents, standards, codes and requirements listed in 2.1, Company Material Specifications, and 2.2, Codes and Standards, in effect on the date of invitation to bid apply to the extent specified herein.

2.1. Company Material Specifications

ZG 301 *General Equipment Base and Enclosure Requirements*

ZG 311 *Concrete Requirements*

ZG 811 *Full Traffic Cover and Frame Assembly*

2.2. Codes and Standards

Western Underground Committee guide

ASTM C857 A-16

AASHTO H-20 (for vaults beneath roadways)

ASTM C857 A-8 (for vaults beneath incidental light truck traffic)

IEEE C2, *National Electric Safety Code (NESC)*

3. Definitions

Company. Refers to PacifiCorp

PacifiCorp. Refers to Pacific Power and Rocky Mountain Power.

4. General

4.1. Application Information

This specification states material and construction requirements which are applicable only to 7' × 12' (94" × 155") manholes.

5. Applicable Stock Item Numbers

Materials being submitted for the following company stock item numbers are subject to evaluation according to the requirements in this specification.

5.1. Stock Item Numbers

7992788, PADVAULT, SWGEAR, 7' × 12' (94" × 155"), TYPE 9&11, 15kV, DF
7992789, PADVAULT, SWGEAR, 7' × 12' (94" × 155"), TYPE 9&11, 25kV, DF
7992790, PADVAULT, SWGEAR, 7' × 12' (94" × 155"), TYPE 3, 15&25kV, 1000KCMIL
7992596, MANHOLE, CONCRETE, 7' × 12' (94" × 155"), FULL TRAFFIC, GG
7992597, MANHOLE, CONCRETE, 7' × 12' (94" × 155"), INCIDENTAL TRAFFIC, GG
3090370, PADVAULT, METERING, 7' × 12' (94" × 155"), 3-PHASE, 600A
7992881, PADVAULT, FUSE CABINET, 7' × 12' (94" × 155"), 15 POSITION

6.5 Design and Manufacturing Requirements

The purpose of a shallow 7' × 12' (94" × 155") vault is to provide an enclosure for cable pulling and padmounted switching.

6.1. Vault Layout

Figure 1 and Figure 2, below, show the assembled shallow 7' × 12' (94" × 155") vault layout with dimensions. Unless otherwise approved by company engineering, all dimensions and placement of hardware shall conform to those shown in Figure 1 and Figure 2. All vault enclosures shall be constructed to AASHTO H-20 (full-traffic) standards, regardless of the cover and frame assembly used.

6.2. Lifting Attachments

Enough lifting attachments shall be provided to ensure safe installation of all pieces at the site.

6.3. Pulling Attachments

Cable pulling attachments shall be installed opposite each set of TERM-A-DUCT banks, such that blocks may be attached for a straight cable pull. Pulling attachments shall have a minimum pullout strength of 6000 pounds. Attachments shall allow the attachment of a clevis with a one-inch diameter through-bolt. Pulling attachments may be designed by the manufacturer to meet these requirements.

6.4. Conduit Entrances

Each end wall: Two (2) banks of six (6) 6.63", and two (2) 2.38", TERM-A-DUCT at each side, as shown in Figure 2

Each side wall: Two (2) banks of six (6) 6.63" TERM-A-DUCT at each end, as shown in Figure 2.

6.5. Incidental Traffic Access Panels

Two access panels, each with an opening no greater than 24" × 60", as specified in ZG 811, shall be included with the assembly.

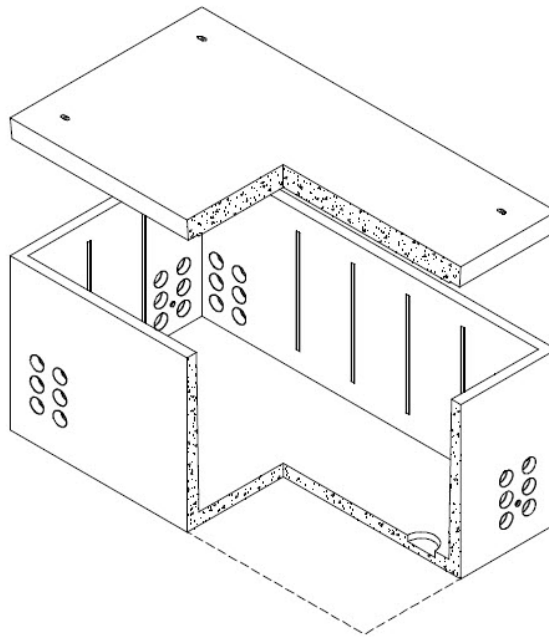

Figure 1— 7' × 12' (94" × 155") Shallow Vault, Cutaway View

ZG 711 Vault—Shallow, 7' × 12' (94" × 155")

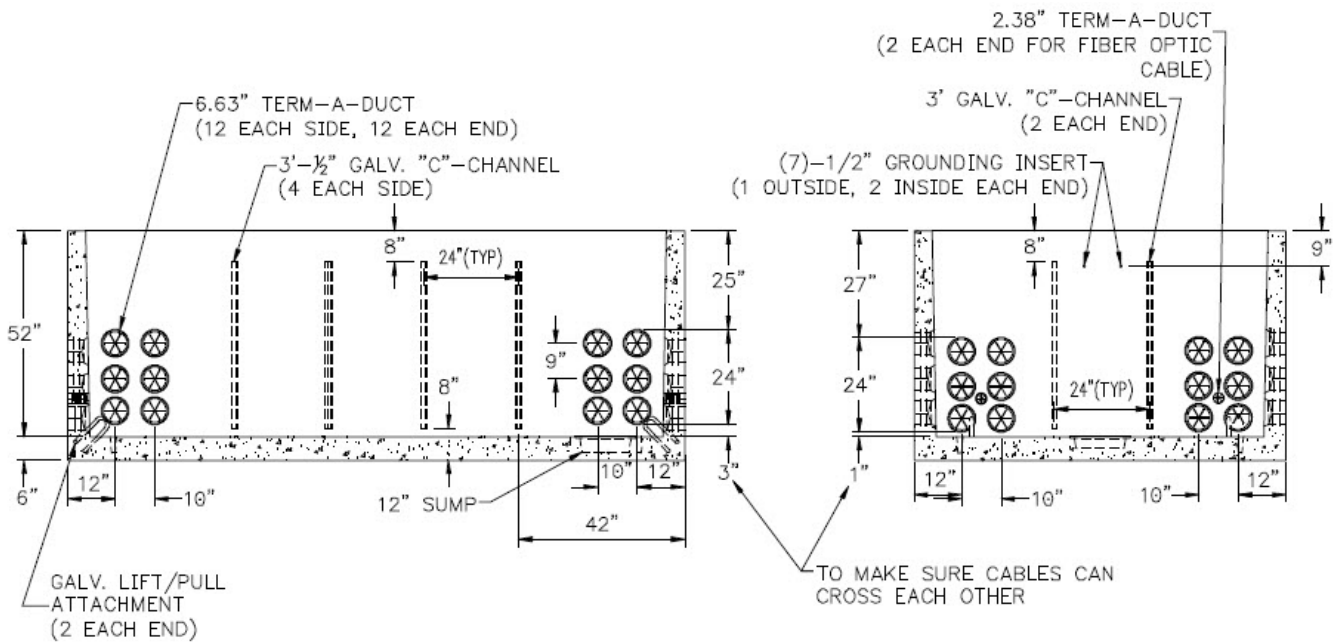

Figure 2— 7' × 12' (94" × 155") Shallow Vault Enclosure Layout

6.6. Ground Grid

The padvault shall be built with an internal, encased electrode in the base of the padvault meeting NESC and consisting of 3/8" steel rebar. The electrode in the base shall be encased horizontally and run continuously around the vault base. The grounding system shall attach to connection inserts made of high-bronze alloy and threaded to 0.5"-13UNC. Each end (short wall) shall have two (2) inserts inside and one (1) insert outside, as shown in Figure 3. One (1) additional grounding insert shall be located on the lid, close to the access door. All inserts shall have caps or plugs installed.

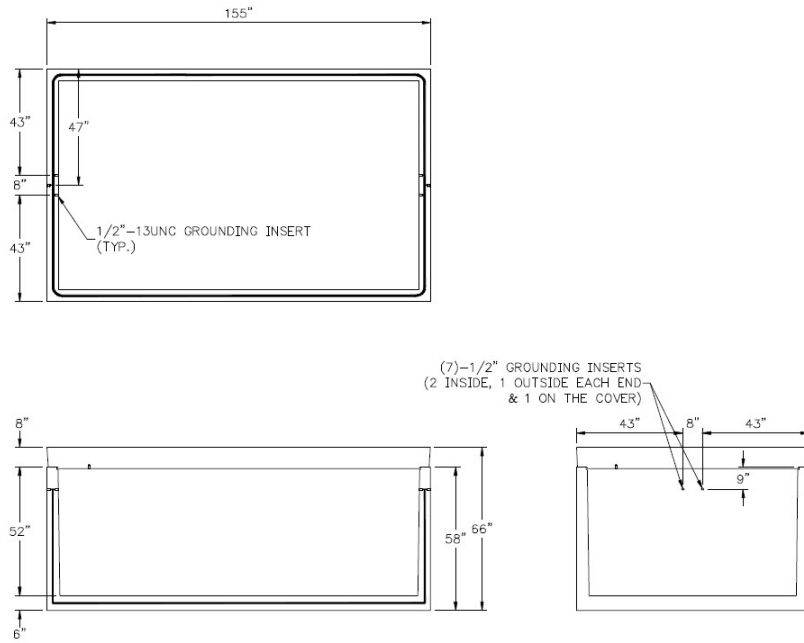

Figure 3— 7' × 12' (94" × 155") Shallow Vault Ground Grid Layout

6.7. Installation

This unit shall be set at the site by the supplier. The contractor is responsible to ensure that all earth under the vault is compacted and leveled to no more than 2% slope prior to setting the vault. A clean gravel base under the pad may be necessary in areas where drainage is poor. The interface between the cover/frame assembly and the enclosure should be sealed using a waterproof substance, such as tar or mastic. The top of the frame should be flush with final grade in pedestrian areas. Setting depth shall be determined by the local regulatory authority for full-traffic areas.

7. Testing

7.1. Test Compliance

Vaults submitted under this specification shall meet all tests and requirements contained in ZG 301 *General Equipment Base and Enclosure Requirements*, ZG 311 *Concrete Requirements*, and this specification. Vaults shall also comply with requirements in applicable national standards.

8. Issuing Department

The engineering standards and technical services department of PacifiCorp published this material specification. This material specification shall be used and duplicated only in support of company projects.