

**Material Specification**

**Sleeve—15, 25, and 35 kV, 600-Amp, Deadfront  
Switchgear, Padvault**

**Standards Engineering Department**

Date: 13 Jul 12

© 2012 by PacifiCorp. All rights reserved.

## Contents

SECTION	PAGE
1 Scope .....	1
2 Applicable Documents .....	1
2.1 PacifiCorp Material Specifications .....	1
2.2 Codes and Standards .....	1
3 General .....	1
3.1 Application Information .....	1
4 Applicable Stock Item Numbers .....	1
4.1 Stock Item Numbers .....	1
5 Design and Manufacturing Requirements .....	2
5.1 Padvault Design and Sleeve Layout .....	2
5.2 Conduit Entrances .....	2
5.3 Lifting Attachments .....	2
5.4 "C"-Channels .....	3
5.5 Grounding Grid .....	3
5.6 Installation .....	5
6 Testing .....	5
6.1 Test Compliance .....	5
7 Issuing Department .....	5
FIGURES	PAGE
Figure 1—Padvault Sleeve .....	2
Figure 2—Sleeve TERM-A-DUCT and "C"-Channel Requirement Detail .....	3
Figure 3—Sleeve Grounding Grid .....	4

# Sleeve—15, 25, and 35 kV, 600-Amp, Deadfront Switchgear, Padvault

## 1 Scope

This specification outlines the minimum requirements for the construction of the padvault sleeve to be used in conjunction with conduit on 15, 25, and 35 kV 600-amp switchgear padvaults. The sleeves are specifically designed to work with the padvaults as foundations for PacifiCorp's 600-amp deadfront switchgear. This specification applies whether the sleeve is to be installed by company personnel, contractor, customer, or the supplier.

## 2 Applicable Documents

The latest revisions of the documents, standards, codes and requirements listed in 2.1, *PacifiCorp Material Specifications*, and 2.2, Codes and Standards, in effect on the date of invitation to bid apply to the extent specified herein.

### 2.1 PacifiCorp Material Specifications

ZG 301, *General Equipment Base and Enclosure Requirements*

ZG 311, *Concrete Requirements*

ZG 562, *Padvault — 7' × 12' (94" × 155") for 600-Amp, Deadfront Switchgear*

### 2.2 Codes and Standards

Applicable codes

ANSI standards

IEEE standards

NEMA standards

## 3 General

### 3.1 Application Information

This specification states material and construction requirements that are applicable only to padvault sleeve for 15, 25, and 35 kV, 600-amp, deadfront switchgears.

## 4 Applicable Stock Item Numbers

Materials being submitted for the following PacifiCorp stock item numbers are subject to evaluation in accordance with requirements in this specification.

### 4.1 Stock Item Numbers

7999125, SLEEVE, PADVAULT, CONCRETE, 7' × 12' × 3.5'

#### MATERIAL SPECIFICATION Distribution

© 2012 by PacifiCorp. All rights reserved.

#### Sleeve—15, 25, and 35 kV, 600-Amp, Deadfront Switchgear, Padvault



13 Jul 12

**ZG 715**  
Page 1 of 6

# ZG 715

## 5 Design and Manufacturing Requirements

### 5.1 Padvault Design and Sleeve Layout

The sleeve shall be designed to fit between the switchgear padvault base and the flat lid, see Figure 1. The padvault sleeve shall have an internal grounding system with internal and external bushings for connecting grounding conductors. Figure 1 below shows the general layout of the padvault sleeve.

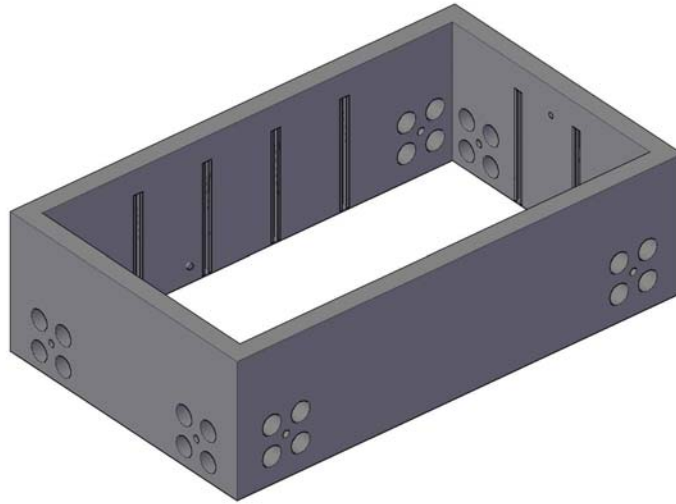

Figure 1—Padvault Sleeve

### 5.2 Conduit Entrances

The padvault sleeve shall also have TERM-A-DUCT entrances to simplify conduit connections as follows:

Each end wall: Two banks of four 6.63" and two 2.38" TERM-A-DUCTS located as shown in Figure 2.

Each side wall: Two banks of four 6.63" and two 2.38" TERM-A-DUCTS located as shown in Figure 2.

### 5.3 Lifting Attachments

Enough lifting attachments shall be provided to ensure safe installation at the site. All lifting attachments shall be galvanized.



**5.4 “C”-Channels**

The padvault sleeve shall have 1 5/8" × 13/16" “C”-Channels embedded into the sleeve walls as described below:

Each side wall: Four 3' sections on each long wall as shown in Figure 2.

Each end wall: Two 3' sections on each short wall as shown in Figure 2.

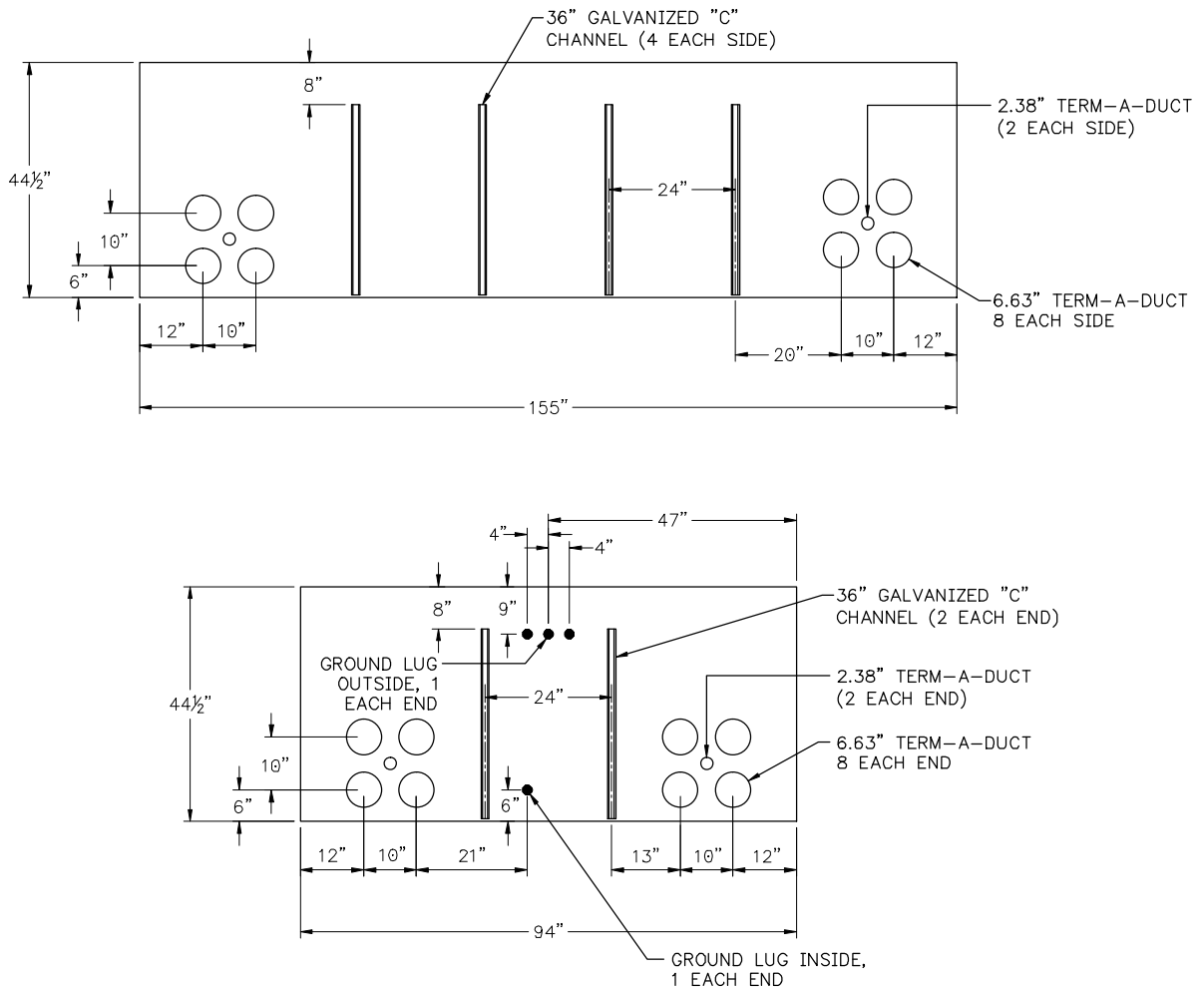

Figure 2—Sleeve TERM-A-DUCT and “C”-Channel Requirement Detail

**5.5 Grounding Grid**

The sleeve shall be built with an internal, encased electrode in the middle of the sleeve meeting NESC 094.B.6. The electrode shall be 3/8" steel rebar. The electrode in the sleeve shall be encased horizontally and run continuously around the sleeve. The grounding system shall attach to connection inserts made of high-bronze alloy and threaded to 0.5"–13UNC. All inserts shall have caps or plugs installed. The sleeve

**MATERIAL SPECIFICATION  
Distribution**

© 2012 by PacifiCorp. All rights reserved.

**Sleeve—15, 25, and 35 kV,  
600-Amp, Deadfront  
Switchgear, Padvault**



13 Jul 12

**ZG 715**  
Page 3 of 6

# ZG 715

shall have three ground lugs on the upper section of each end wall, and one ground lug on the lower section of each end wall, for a total of eight ground lugs. Refer to Figure 3 for specific layouts.

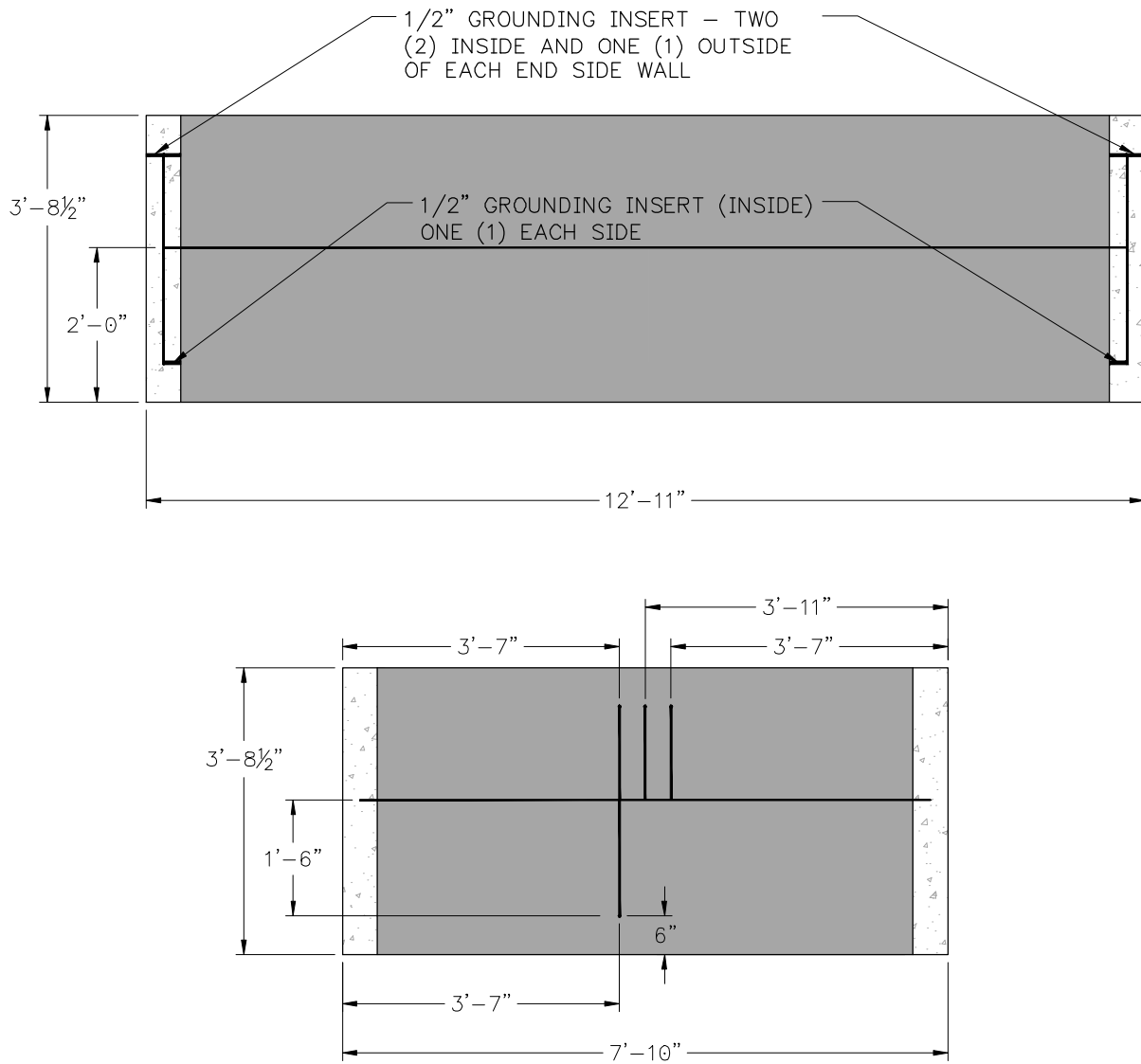

Figure 3—Sleeve Grounding Grid



**Sleeve—15, 25, and 35 kV,  
600-Amp, Deadfront  
Switchgear, Padvault**

**MATERIAL SPECIFICATION  
Distribution**

© 2012 by PacifiCorp. All rights reserved.

**5.6 Installation**

The padvault sleeve shall be off-loaded and set by the padvault supplier to maintain warranties, unless there are extenuating circumstances. Site and excavation conditions shall be as required by the padvault supplier to ensure proper placement. The excavation for the padvault shall include six inches of compacted gravel, graded level. The joint between the vault pad, sleeve, and the enclosure shall be sealed with the gasket and sealant provided by the padvault supplier.

**6 Testing**

**6.1 Test Compliance**

Padvaults submitted under this specification shall meet all tests and requirements contained in ZG 301, *General Equipment Base and Enclosure Requirements*; ZG 311, *Concrete Requirements*; and this specification. Padvaults shall also comply with requirements in applicable national standards.

**7 Issuing Department**

The Engineering and Asset Management Documentation department of PacifiCorp published this document. This document shall be used and duplicated only in support of PacifiCorp projects.

# ZG 715

This page is left blank intentionally.

